



1 IEC Grade (IEC 61646, Safty Class II (CE))

	G-TYPE	T-TYPE	
Model	G-EA060	T-EC120	T-ED120
Nominal Power (W)	60.0	120.0	120.0
Open Circuit Voltage (V)	91.8	91.8	91.8
Short Circuit Current (A)	1.19	2.38	2.38
Maximum Power Voltage (V)	67.0	67.0	67.0
Maximum Power Current (A)	0.90	1.80	1.80
Maximum System Voltage (V)	530	530	530
Dimensions (mm)	L960×W990×D40	L1918.8×W990×D46	L960×W1978.8×D46
Weight (kg)	13.7	27.5	27.0
Connector	MC	MC	MC

2 UL Grade (cUL^{US} LISTED CEC Registered)

	G-TYPE	T-TYPE	
Model	G-SA060	T-SC120	T-SD120
Nominal Power (W)	60.0	120.0	120.0
Open Circuit Voltage (V)	91.8	91.8	91.8
Short Circuit Current (A)	1.19	2.38	2.38
Maximum Power Voltage (V)	67.0	67.0	67.0
Maximum Power Current (A)	0.90	1.80	1.80
Maximum System Voltage (V)	530	530	530
UL Fire Rating	Class C	Class C	Class C
Fuse Rating (A)	7.0	7.0	7.0
Dimensions (mm)	L960×W990×D40	L1918.8×W990×D46	L960×W1978.8×D46
Weight (kg)	13.7	27.5	27.0
Connector	MC	MC	MC

3 Low Voltage (IEC 61646, cUL^{US} LISTED)

	P-TYPE
Model	P-LE055
Nominal Power (W)	55.0
Open Circuit Voltage (V)	23.0
Short Circuit Current (A)	4.68
Maximum Power Voltage (V)	16.5
Maximum Power Current (A)	3.33
Maximum System Voltage (V)	49
Dimensions (mm)	L990×W990×D40
Weight (kg)	14.4
Connector	none

Warranty

●G-TYPE, T-TYPE

25-year power output warranty

G-TYPE, T-TYPE PV modules will maintain more than 80% of minimum rated power for 25 years (based on data from silicon PV modules installed over a month under conditions of 25°C, A.M. 1.5 and 100m W/cm²)

●P-TYPE

10-year power output warranty

P-TYPE PV modules will maintain more than 90% of minimum rated power for 10 years (based on data from silicon PV modules installed over a month under conditions of 25°C, A.M. 1.5 and 100m W/cm²)

* Data listed herewith are standard values measured using the JIS testing method but are not guaranteed values.

* The PV systems's power-generating capacity is represented by the total of individual PV module power outputs calculated based on the JIS.

Power output under actual usage conditions can vary depending on the level of solar radiation, installation conditions (directions, angles and ambient conditions), regional climates and temperature.

* Specifications are subject to change without notice.

* JIS : Japanese Industrial Standards

G-EA060/G-SA060

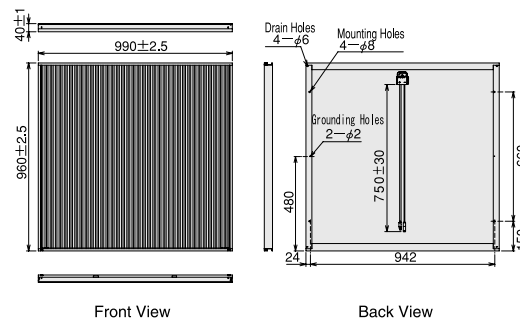

P-LE055

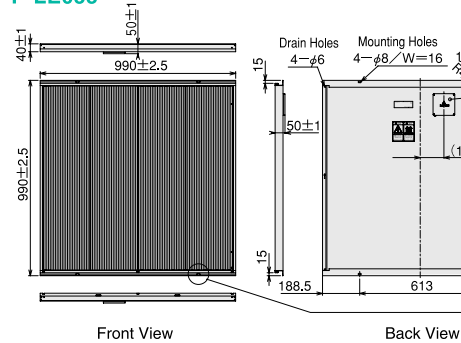

T-EC120/T-SC120

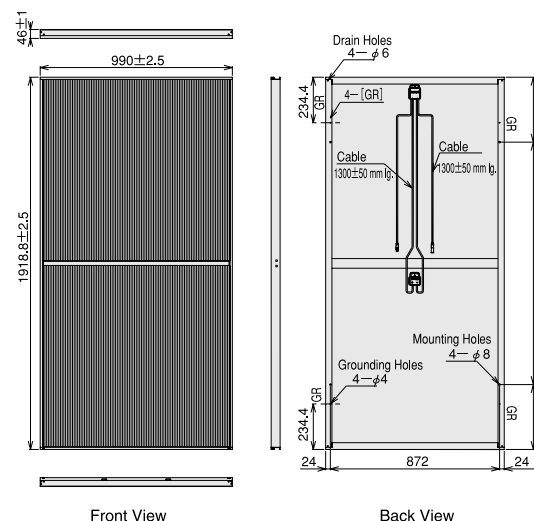

T-ED120/T-SD120

