

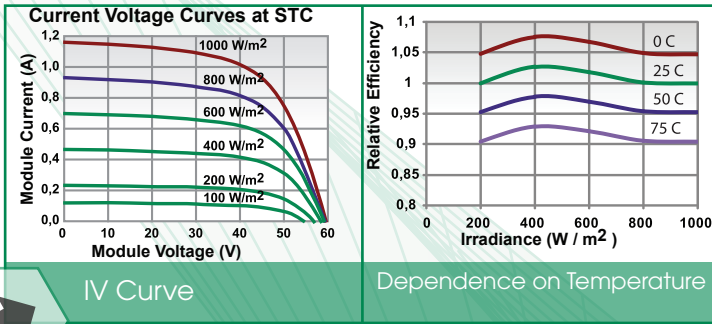

EPV-4X, EPV-5X

Solar Module

Advanced Thin-film Photovoltaic Technology



IV Curve

Dependence on Temperature

Electrical Specifications

		EPV-4X Series		EPV-5X Series				
		40W	42W	50W	52W	54W	56W	58W
Rated Power (+/- 5%)	Pmax (W)	40	42	50	52	54	56	58
Voltage at Maximum Power	Vmp (V)	44	45	45.0	45.5	45.4	46.2	46.5
Current at Maximum Power	Imp (A)	0,92	0,94	1.12	1.15	1.19	1.22	1.25
Open Circuit Voltage	Voc (V)	59	60	60	60	60.6	61.7	62.3
Short Circuit Current	Isc (A)	1,17	1,18	1.41	1.44	1.49	1.51	1.54
Maximum System Voltage	Vsys (V)	1,000V (IEC) / 600V (UL)						
	IEC / UL							
Temperature Coefficient of Pmax	Tk (Pmax)	-0,19 %/°C						
Temperature Coefficient of Voc	Tk (Voc)	-0,28 %/°C						
Temperature Coefficient of Isc	Tk (Isc)	+0,09 %/°C						

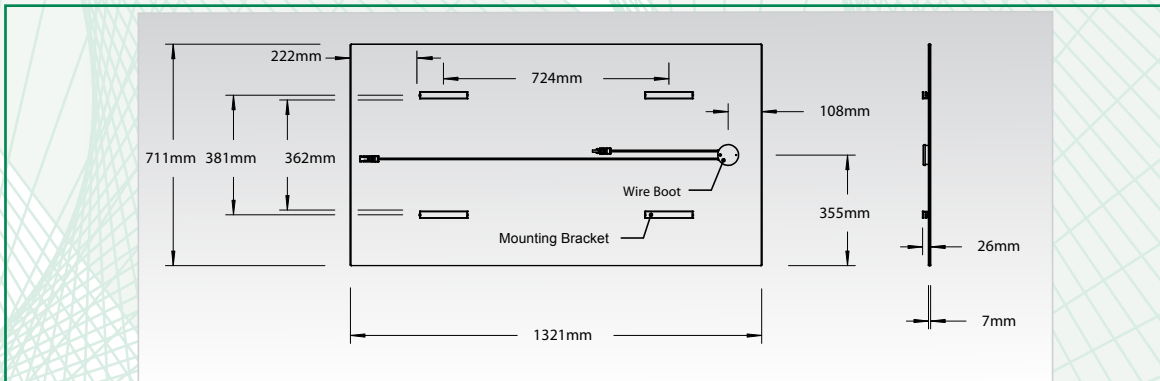

Diagram for EPV-5X Series Measurements

Mechanical Specifications

	EPV-4X Series	EPV-5X Series
Length	1245 mm +/- 3 mm	1321 mm +/- 3 mm
Width	635 mm +/- 3 mm	711 mm +/- 3 mm
Thickness (including wiring boot)	7 mm (24 mm including wiring boot)	
Weight	12,3 kg	14,5 kg
Module Area	0,79 m ²	0,94 m ²
Bypass Diode	None	
Module Type	a-Si (amorphous silicon)	
Frame Material	Frameless	
Glass Type	0.125 in / 3 mm annealed glass on front and back	
Encapsulation	EVA (ethylene vinyl acetate)	
Output Cable / Connectors	14 AWG single insulated or 2.5mm double insulated with quick connect connector	



CAUTION: READ USER'S GUIDE BEFORE USING THIS PRODUCT

Electrical specifications are rated at Standard Test Conditions STC (Irradiance of 1000W/m², AM 1.5, cell temperature 25°C). During the stabilization process that occurs during the first few months in service, module power output will exceed specified ratings. Power output may be higher by 20%; operating voltage may be up to 10% higher; operating current may be up to 14% higher; and short circuit current may be up to 10% higher.

Warranty

- 25 year limited power output (80%)
- 2 year limited workmanship or materials

Certifications

- DIN EN 61646:1998-03, EN 61646:1997 e IEC 61646 (ed 1) certified by VDE
- Safety Class II according to DIN VDE 0110-1:2003-11, IEC 61730-1 and IEC 61730-2.
- Conforms to UL 1703 and ULC/ORD-C1703-1
- 2400 N/m² mechanical load-bearing capacity, for both the module and the interface with the mounting system (backside brackets) per IEC 61646.
- Repeated measurements of the electrical parameters and insulation properties during the manufacturing process
- Product tested by independent recognized laboratories..

Stabilization values

During the stabilizations process that occurs during the first months in service, module power output will exceed specified ratings. Power output may be higher by 20%, operating voltage may be up to 10% higher, operating current may be up to 14% higher, and short circuit current may be up to 10% higher.

Applications

- Grid-tied systems
- Off-grid systems
- On rooftops
- Free-standing
- For BiPV applications please refer to specific products.

Advantages

- High temperature and low light performance
- Shadow tolerance
- High efficiency under low radiation conditions.
- Very low mismatch effects
- New flexible mounting systems

Inverter selection

The selection of the inverter should be done in accordance of avoiding negative voltages on the solar generator against ground. Therefore, EPV Solar recommends the use of inverter topologies/designs which allow and secure having ground potential or similar at the negative pole of the solar array.

Shading and bypass diodes

According to the internal cell structure of EPV modules, no bypass or blocking diodes are required as long as the connection of a maximum of 8 strings in parallel is observed

In case of possible shading, please install the modules observing that laser lines run perpendicularly to the shadow. In this way the relationship between the shaded area and the output loss will be linear.

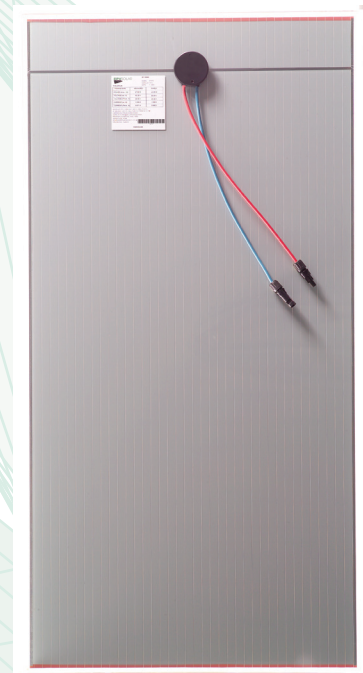
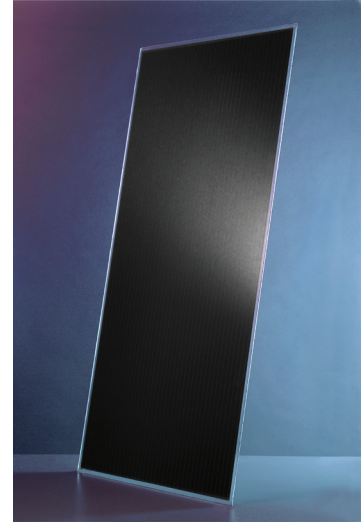

USA

EPVSOLAR USA

8 Marlen Drive
Robbinsville, New Jersey 08691 USA
Ph: 1.609.587.3000 Fax: 1.609.587.5355

www.epvsolar.com
sales@epvsolar.com

Modifications to technical data are possible without prior notice. Please request the current data sheets from EPV SOLAR before using our products. EPV SOLAR assumes no responsibility for damage caused to equipment connected to EPV modules that are not operated in accordance with the relevant technical information. The instructions in the Installation and User Guides must always be observed (i.e. max 8 strings in parallel without external protection, use of compatible inverters). In case of any question please do not hesitate to contact our technical team.